

DC motor with optical encoder

OEM

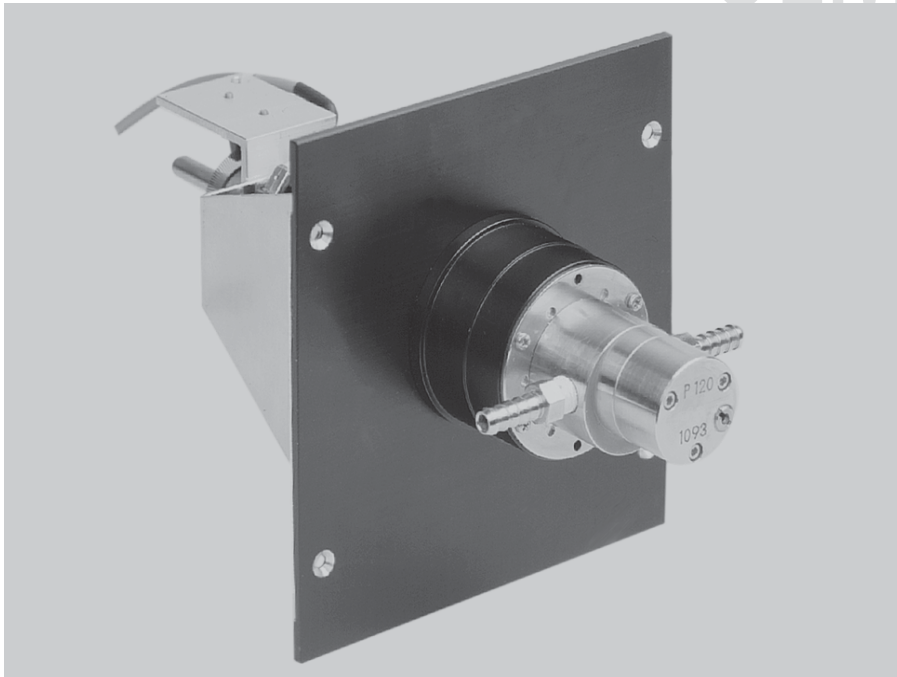

Side view (mm)

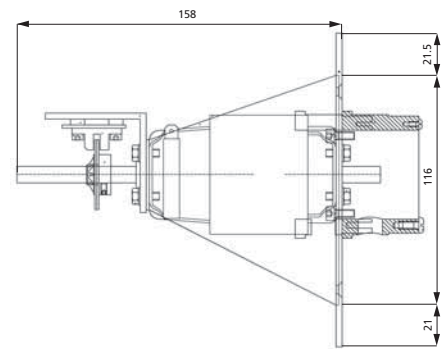

Front view (mm)

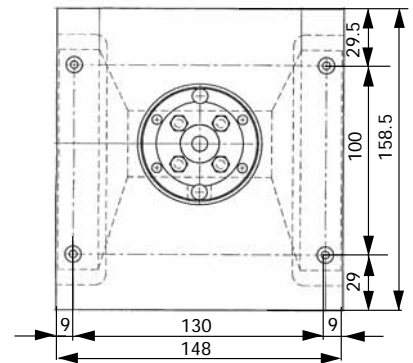

Mounting cut-out (mm)

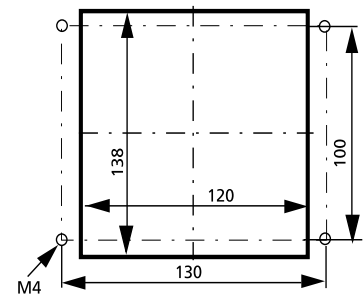
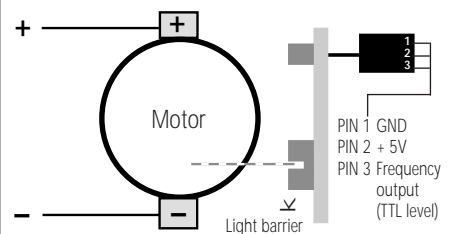

Diagram and electrical connections



*

Please note

Specifications valid for the following ISMATEC® control units.

BVP-E Z - see data sheet 08.11
MCP-E Z - see data sheet 08.12

Technical specifications

Pump model	MCP-E Z
Motor type	DC motor with encoder
Rotation speed*	60-6000 rpm
Flow rates*	1-7241 ml/min
Motor control*	optional control unit
Power consumption	max. 180 W
Optical encoder	120 impulses/motor rev.
Channels	1
Weight	1.6 kg
* See 'Please note'	

Please ask for data sheets with an exact description of the gear pump-head.

Gear pumphead, magnet and nipples not included.

Flow rates¹⁾

Pump head	ml per revolution	Differential pressure	Gear material
186	0.016	1.4 ³⁾	Graphite
181	0.042	2.8 ³⁾	Graphite
183	0.084	2.8 ³⁾	Graphite
1830	0.093	5.2 ³⁾	PPS or PEEK
200 ²⁾	0.584	5.2 ³⁾	PPS or PEEK
120 ²⁾	0.658	3.5 ³⁾	PTFE or PEEK
130 ²⁾	0.658	5.2 ³⁾	PPS or PEEK
140	0.658	3.5 ³⁾	PTFE or PEEK
150	0.658	5.2 ³⁾	PPS or PEEK
122 ²⁾	0.913	3.5 ³⁾	PTFE or PEEK
142	0.913	3.5 ³⁾	PTFE or PEEK
201 ²⁾	1.207	3.5 ³⁾	PPS or PEEK

¹⁾ Water, without differential pressure
²⁾ with bypass ³⁾ Other values possible on request
System pressure: max. 21 bar

k Calculation example for flow rate
rpm x ml per revolution = ml/min
6000 x 1.207 = 7241

Ordering information

Nominal voltage	Type MCP-E Z	Order No.
24 V _{DC}		IS 3968
	Gear pumphead, magnet and nipples are not included.	