

# DC motor with optical encoder and gear box

OEM

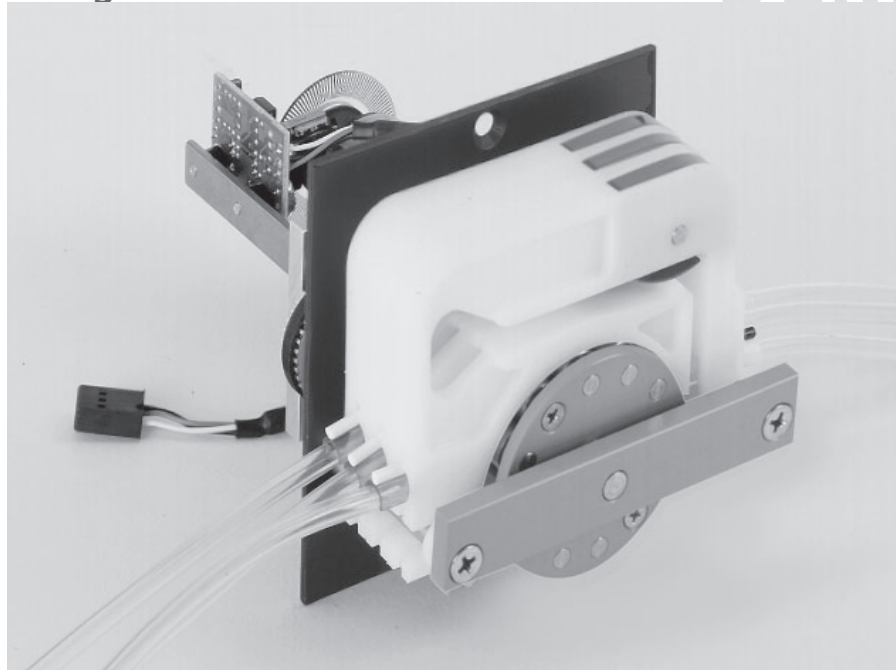

Side view (mm)

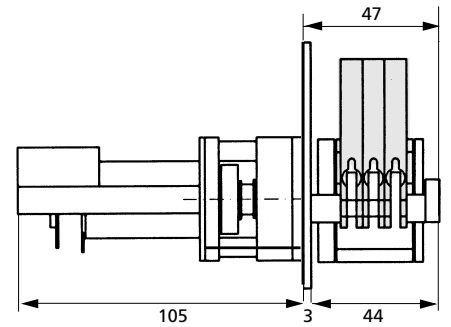

Front view (mm)

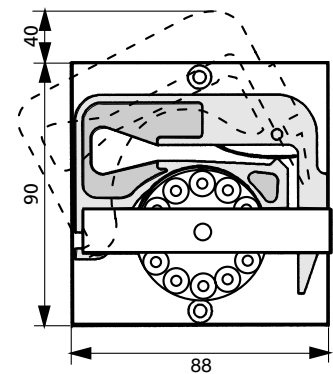

Mounting cut-out (mm)

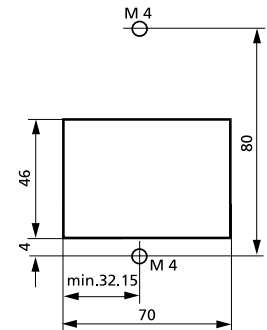
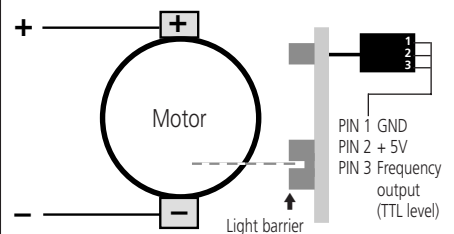

Diagram and electrical connections



## Technical specifications

Pump model	REGLO-E MS/CA3-12
Motor type	DC motor with encoder
Gear ratio	25:1
Rotation speed*	2–100 rpm <sup>a)</sup> 1–100 rpm <sup>b)</sup>
Flow rates*	0.001–24 ml/min
Motor control*	optional control unit
Power consumption	max. 10 W
Optical encoder	120 impulses/motor rev.
Channels	3
Pump rollers	12
Weight	0.700 kg
Tubing type	3-stop collared tubing
Tubing i.d.	0.13–3.17 mm
Cassettes	MS/CA Click'n'go, POM

**Cassettes (Spare part / Option)**  
 IS 3510 MS/CA Click'n'go, POM-C <sup>2)</sup>  
 IS 0649 MS/CA Pressure lever, POM-C  
 IS 3629 MS/CA Pressure lever, PVDF

<sup>2)</sup> Standard equipment  
 ➔ Please see data sheet 09.1

## Flow rates<sup>1)</sup>

Tubing i.d. mm	ml per revolution	Tubing i.d. mm	ml per revolution
0.13	0.00093	1.14	0.067
0.19	0.0021	1.22	0.075
0.25	0.0038	1.30	0.083
0.38	0.0088	1.42	0.094
0.44	0.012	1.52	0.10
0.51	0.016	1.65	0.12
0.57	0.019	1.75	0.13
0.64	0.024	1.85	0.13
0.76	0.033	2.06	0.15
0.89	0.044	2.29	0.17
0.95	0.050	2.54	0.19
1.02	0.056	2.79	0.21
1.09	0.063	3.17	0.24

<sup>1)</sup> Water, Tygon® tubing, without differential pressure

➔ Calculation example for flow rate  
 rpm x ml per revolution = ml/min  
 100 x 0.24 = 24

Ask for the ISMATEC®  
 Pump Tubing Selection Guide.

## Ordering information

Data sheet	Nominal voltage	Type REGLO-E MS/CA3-12	Order No.
	12 V <sub>DC</sub>		IS 3266

02.3.12  
 30.09.05

## \* Please note

Specifications valid for the following ISMATEC® control units:  
<sup>a)</sup> REGLO-E Analog - see data sheet 08.1  
<sup>b)</sup> REGLO-E Digital - see data sheet 08.2